

(No Model.)

3 Sheets—Sheet 1.

J. CHASE.  
SLIDE KNIFE LATHE.

No. 289,978.

Patented Dec. 11, 1883.

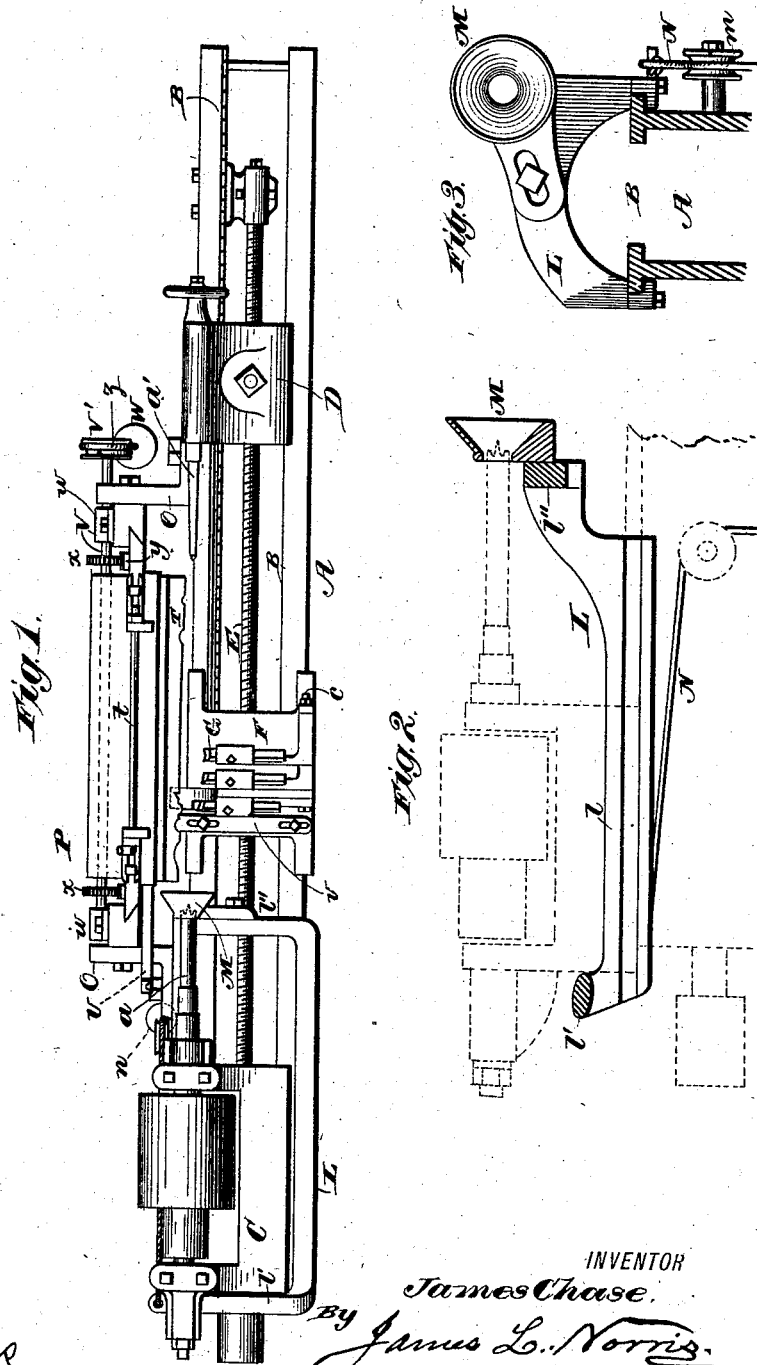

WITNESSES  
*Robert Everett,*  
*Vinton Coombs*

INVENTOR  
*James Chase,*  
By *James L. Norris,*  
Attorney

J. CHASE.  
SLIDE KNIFE LATHE.

No. 289,978.

Patented Dec. 11, 1883.

Fig. 4.

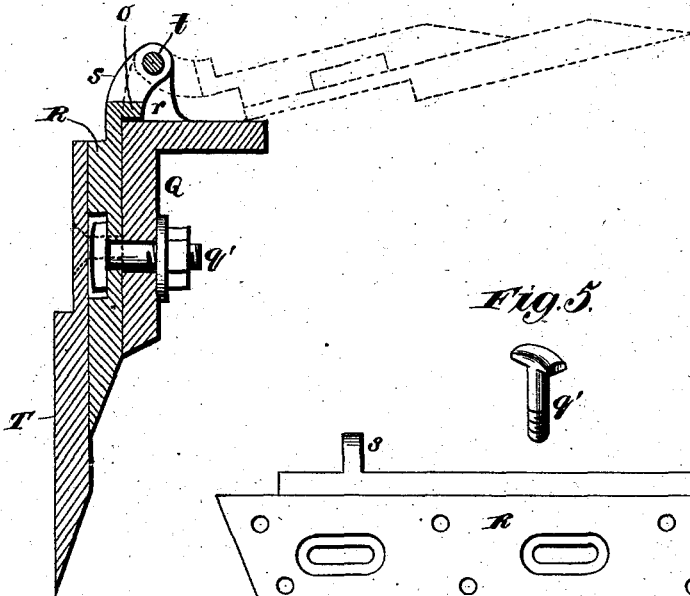

Fig. 5.

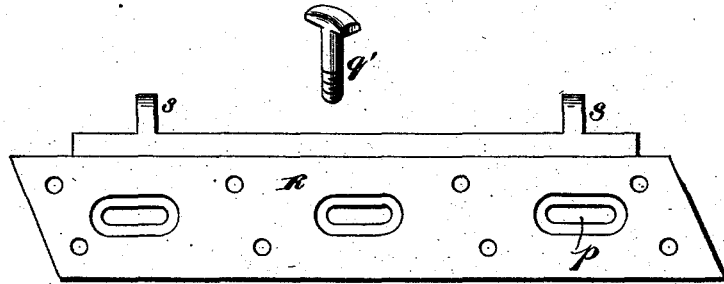
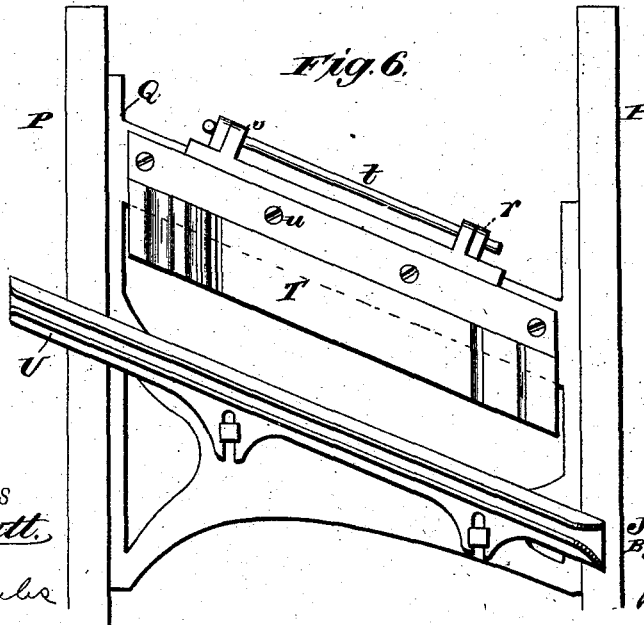

Fig. 6.



WITNESSES  
*Phil. Smith*  
*Anton Paulus*

INVENTOR  
*James Chase.*  
 By *James L. Norris.*  
 Attorney

(No Model.)

3 Sheets—Sheet 3.

J. CHASE.  
SLIDE KNIFE LATHE.

No. 289,978.

Patented Dec. 11, 1883.

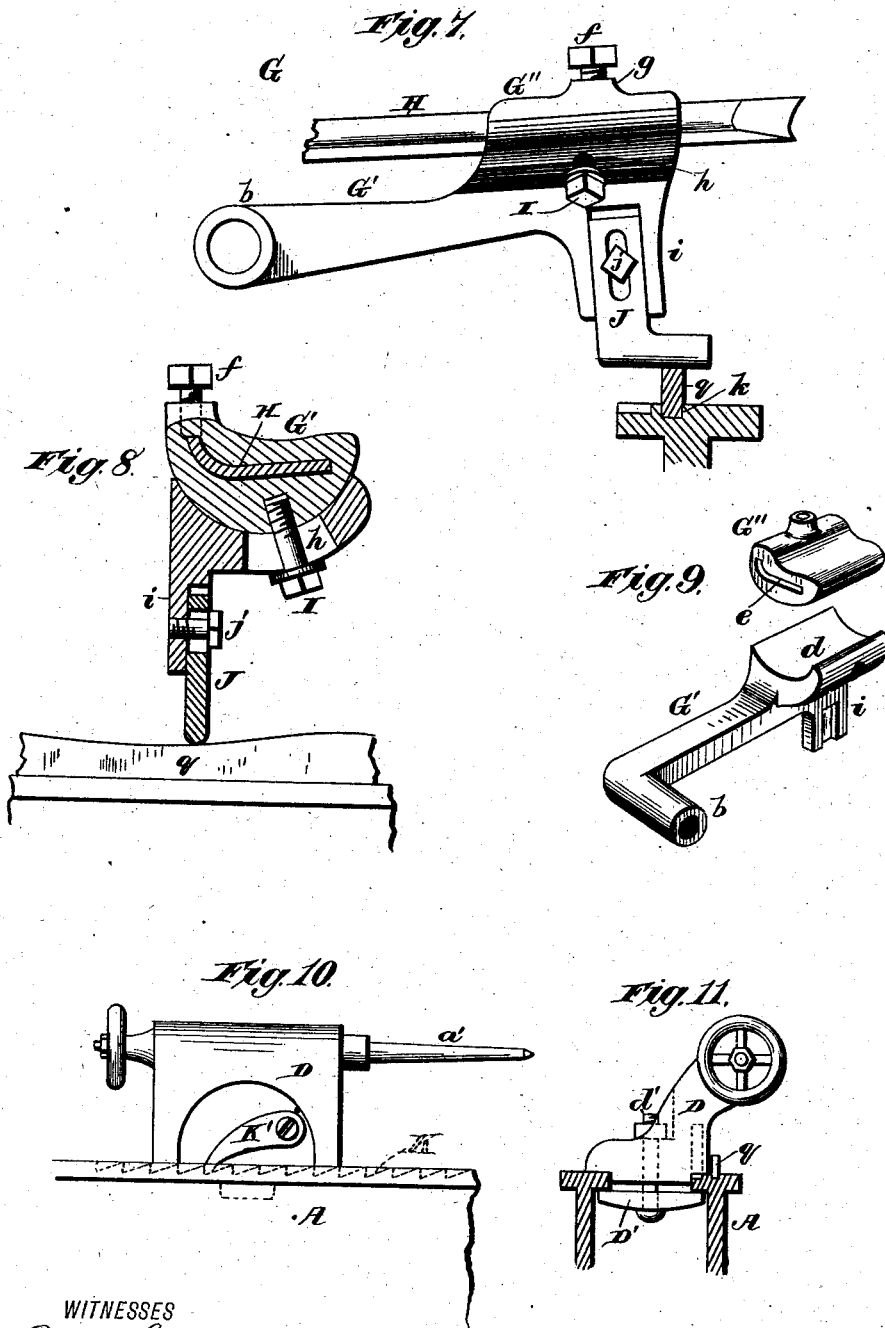

WITNESSES  
*Robert Everett*  
*Vinton Cosmides*

INVENTOR  
*James Chase,*  
By *James L. Norris,*  
Attorney

# UNITED STATES PATENT OFFICE.

JAMES CHASE, OF ROCHESTER, NEW YORK.

## SLIDE-KNIFE LATHE.

SPECIFICATION forming part of Letters Patent No. 289,978, dated December 11, 1883.

Application filed June 21, 1883. (No model.)

*To all whom it may concern:*

Be it known that I, JAMES CHASE, a citizen of the United States, residing at Rochester, New York, have invented new and useful Improvements in Slide-Knife Lathes, of which the following is a specification.

My invention relates to shear or slide knife lathes for turning wood, and has for its objects to provide a centering attachment, by means of which the centers and carriage are held absolutely in line, and to overcome the necessity of removing the pattern-cutter or shear-knife when it is to be sharpened, and the resultant annoyance and labor of packing and forcing back the knife or cutter to its proper position, and to simplify the manner of adjusting the smoothing or tapering chisel. These objects I accomplish by the novel construction and combinations of parts hereinafter described and claimed, and illustrated in the accompanying drawings, in which—

Figure 1 is a plan of the lathe; Fig. 2, a vertical longitudinal section through the centering attachment, the head-block attachments being shown in dotted lines. Fig. 3 is a transverse section in front of the centering attachments, showing the manner of attaching the conical or flaring cup. Fig. 4 is a vertical transverse section through the gate, knife, and plate, showing the manner of connecting the parts and bringing them so as to throw the knife back to the position shown in dotted lines. Fig. 5 is a perspective detached view of the knife-clamping plate and bolt. Fig. 6 is a perspective detached view of the sliding gate, showing the manner of setting the knife diagonally therein, and the diagonally-set grooved or slotted bar through which the gate is raised and lowered. Fig. 7 is a side view of the smoothing-knife stock detached, showing, also, the adjusting-step or templet and the way in which it rests. Fig. 8 is a transverse section of the same; Fig. 9, a perspective of the stock, detached from other parts, and having its two parts separated. Fig. 10 is a side view of the tail-block, showing the dog pivoted thereto and the ratchet in the bedway; and Fig. 11 is an end view of the same, showing the manner of clamping the block to the ways.

In the said drawings, the letter A indicates the lathe-bed, which has the ways B, which are

planed, as usual, on their upper surfaces, their two inner and outer edges, and the under side of the outer edges. The usual head-block, C, and tail-block D, are also planed and shouldered to the inner edges of the ways, so as to keep the centers *a a'* in line. The feed-screw E passes through the carriage F—that is, intermediate the two blocks. The carriage F is provided with the roughing-gage, a die through which the stock is passed for support, and a reducing-knife whose stock is hinged at its outer end and made to ride upon any desired templet, to give it the required cut.

The parts so far referred to are of the ordinary construction and application, and so need not more fully be described or illustrated.

In addition to the reducing-knife, there is also employed a smoothing or tapering knife, G, used, mainly, to give a finish to tapered plain stock, and in such cases to take the place of the more expensive shear-knife. The stock of this smoothing-knife I construct of two parts, *G' G''*, the part *G'* being formed at its outer end with a sleeve, *b*, at right angles to its length, to receive the bolts *c*, by which it is hinged to the carriage, and at its inner end with a concave socket, *d*, to receive the part *G''*, the under face of which is convex, to conform to the shape of the socket, while its upper face may be flat or other shape, but preferably depressed, as shown. The part *G''* is formed through it longitudinally a curved or tapering slot, *e*, to receive the curved or tapering cutter or knife H, which is held in the slot by a set-screw, *f*, passed through a hole made in the top face downward, and preferably having a raised collar, *g*, around it, which affords a strong bearing for the set-screw. The knife-clamp *G''* is held to its socket-support by a bolt, *l*, passed through an elongated slot, *h*, made through the bottom of the socket and entering a threaded opening in the clamp. By loosening the bolt, the clamp can be turned so as to adjust the knife to any angle or inclination desired. The socket end of the part *G'* is formed with a downwardly-extending flange, *i*, one face of which is recessed to receive one arm of the step J, which is held thereto by a bolt or screw, *j*, passing through an elongated slot in that end and into the flange, the elongated slot permitting the cutter to be set at any desired height. This step

rests by its lower arm upon the templet *g*, which fits into a groove, *k*, formed in the way of the bed, as clearly shown in Fig. 7 of the drawings. If desired, the reducing-knife may be adjusted as to height in the same manner.

In order to rigidly fasten the tail-block D at any desired point, a ratchet-bar, K, is cast or otherwise formed in the upper face of the way, next to the shear, as shown in Figs. 1 and 10, and a pawl or dog, K', is pivoted to the tail-block at or near its inner end, so as to engage with the ratchet-bar in such a manner as to receive, as far as is possible, the direct strain consequent upon putting the stock into the center for turning. The tail-block is held to its place by a bolt, *d*', passing through it from top to bottom, the nut being at the top and the head at the bottom, so as to hold a cross-bar, D', up against the under side of the inner ways of the bed, as shown in Fig. 11, and thereby clamp the blocks to the ways.

For the purpose of causing both the centering attachments and the carriage to move absolutely in line, I cast or otherwise make the centering attachment L in the form of a frame, cast or otherwise made with two longitudinal parallel side bars or guides, *l*, and two transverse end bars, *l'*, the frame being made to span or fit around the head-block and to slide upon the ways to which they are gibbed, so as to slide freely thereon, the groove in the longitudinal bars for fitting to the ways being shown in Fig. 2 of the drawings.

To the inner cross-bar, *l'*, of the frame I attach a flaring or bell-shaped cup, M, through which the driving-center may pass as the frame is worked back and forth, and into which the end of the stick may enter and be directed in line. The bell or conical shaped cup is held to the face of the inner cross-bar by a bolt or screw passed through an elongated slot formed in the extension of the cup and into the bar. By reason of the elongated slot the cup can be adjusted to any position desired, and by simply withdrawing the bolt a cup of another size may be substituted. A cord or chain, N, is connected to the end of the rear cross-bar of the frame, and is carried forward and passed over a sheave-pulley, *m*, on the side of the bed, and a weight, *n*, is connected to its end. When the carriage F comes in contact with the end of the frame, the latter is pushed back, drawing with it the rope and raising the weight, and as the carriage recedes the weight descends and draws forward the frame, so as to bring the conical cup into position for the next stick.

It will be observed that by the construction of the frame described the centering attachment and carriage is kept in line, and that the frame operates automatically to return the conical cup.

To the back of the lathe-bed there are bolted two angle-irons, O, to which, between the two, there are bolted two vertical guides, P, which are grooved vertically on their inside faces, so as to receive the gate Q, which carries the

shear-knife, and is free to slide up and down in the guides, and is provided on its top edge, below its ends, with adjustable ears *r*.

To the inside face of the gate, at its top, there is bolted a knife-plate, R, which has a flange, *o*, at its top, to rest upon the top edge of the gate, and is provided with several longitudinally-elongated holes, *p*, around which the plate is recessed to receive the T-heads of bolts *q*, which pass through the plate and gate, and are provided with washers and nuts at the back of the gate to clamp the plate to the gate. The rear face of the plate, at its lower end, is preferably beveled, as shown, and at its top edge, between the ends of the flange, it is provided with shears *s*, which will fit snug against the ears *r*, and a bolt-rod, *t*, will pass through the ears, so as to hinge the plate to the gate, so that when released from the clamping-bolts the plate may be swung backward, as shown by dotted lines in Fig. 4 of the drawings. The shear-knife T, which in all essentials is of the ordinary construction, is firmly and rigidly secured by screw-bolts *u* to the inner face of the knife-plate, as seen in Figs. 4 and 6 of the drawings.

Heretofore the shear or pattern knife has been clamped direct to the gate, and as it frequently springs in tempering, by reason of its unequal thickness, it has to be packed and forced back to its proper position, and every time it is removed to be sharpened the same packing and forcing-back steps gone through in the first instance have to be repeated. All this difficulty, however, is overcome by clamping the knife to a plate and hinging the latter, so that it may be thrown back, for when the knife is once adjusted to the plate it is allowed to remain so, and when it is to be sharpened, the plate is released from its clamping-bolts and, with the knife connected to it, is swung back, as shown in Fig. 4 by dotted lines, when it may be raised and lowered to suit the convenience of the sharpener. The knife T is set diagonally across the gate, and is brought into action by a finger-bar, *v*, attached to the carrier, and entering the slotted or grooved bar U, which is bolted diagonally to the gate, so that as the carriage is fed forward the gate and knife are drawn down into action in the manner heretofore practiced. There is secured to the guides P by suitable bearings, *w*, a shaft, V, which is provided with gear-wheels *x*, which mesh with racks *y*, secured vertically to the gate Q, and to one end of the shaft, which extends out beyond its bearings, there is secured a pulley, V', from the periphery of which a cord or chain, *z*, extends downward, and has connected to its lower end a weight, W. By such construction the gate and parts attached thereto are nicely counterbalanced, and but little force is required to work the gate up and down.

I am aware that a lathe has been provided with a centering attachment consisting of a bell-shaped cup secured to parallel rods mounted on the sliding head-block, said rods

being connected at each end by bars and adapted to slide on the head-block.

I am aware that the smoothing-knife stock of a lathe has been made adjustable to incline the knife more or less; and I am also aware that vertically-sliding knife-gates are old in lathes, and that swinging knife-holders are not new with me.

What I claim is—

10 1. A self-centering attachment for lathes, constructed with transverse end bars and parallel side bars, each having a longitudinal groove to respectively engage the ways of a lathe-bed, and capable of being applied to an ordinary lathe independently of any connection with the sliding head-block, substantially as described.

20 2. In a lathe, a self-centering attachment having transverse end bars, in combination with a detachably-flaring or conical cup held adjustably to the inner transverse bar, substantially as described.

3. The combination, with the carriage F of a lathe, of the smoothing-knife attachment consisting of the part G', having at its outer end a sleeve, b, at right angles to its length, which is swiveled to the carriage, and provided at its other end with the concave socket d, the knife-carrying part G'', having a convex under side fitting the socket and capable of turning in the socket in the direction the carriage moves transversely to the length of the part G', and a screw-bolt, h, passing upward through the socketed end of the part G' into the knife-carrying part, to hold the latter in position when adjusted transversely, substantially as described.

4. A smoothing-knife attachment for lathes, consisting of two parts, G' G'', the part G' having at one end means to swivel it on the carriage, and at its other end a socketed upper surface, d, and transverse slot h, and the part G'', having its bottom surface constructed to fit the socket, and provided with a longitudinal knife-securing slot, e, and a bolt, I, passing upward through the slot h into the part G'', to adjust the latter transversely on the socket, and thereby vary the angle of the knife, substantially as described.

50 5. In a lathe, the combination of a vertically movable and guided gate, Q, a knife-plate, R, journaled at its upper edge to the

gate, and detachably but rigidly connected with the gate, and the shear-knife T, rigidly attached to the knife-plate, which latter is thereby intermediately the knife and gate, said plate being rigidly held by the gate when the knife is in position to operate on the work, but capable of being detached from the side of the gate to permit it to swing around and rest upon the gate and carry with it the knife, to present the beveled edge thereof to the operator for sharpening, substantially as described.

6. The combination, in a lathe, of a vertically movable and guided gate, Q, having ears r, projecting from its upper edge, the knife-plate R, rigidly but detachably connected with the vertical face of the gate, and having ears s, projecting from its upper edges, the rod t, passing through the ears r and s, and the shear-knife T, rigidly attached to the knife-plate, which latter is thereby interposed between the knife and the gate, and is rigidly held by the latter, when in position, to present the knife to the work, but which can be disengaged from the face of the gate, to permit the knife-plate to swing around on the rod and rest on the upper edge of the gate for presenting the beveled edge of the knife to be sharpened, substantially as described.

7. In a lathe, the combination of upright guides P, a gate, Q, arranged to slide in a vertical line between the guides, a knife-plate, R, swiveled to swing on the gate, and having slots p, bolts q', having heads arranged in the slots for detachably connecting the knife-plate upon the vertical face of the gate, and a shear-knife, T, secured to the knife-plate, over the heads of the bolts q, substantially as described.

8. In a lathe, the combination, with the bed and its ways, of the self-centering attachment composed of the parallel and transverse bars clasped to the ways, and having the flaring or conical cup provided with a slotted extension, secured to the inner transverse bar by a screw-bolt, substantially as described.

In testimony whereof I have hereunto set my hand in the presence of two subscribing witnesses.

J. CHASE.

Witnesses:

J. A. RUTHERFORD,

JOS. L. COOMBS.